

70 SERIES

70 Series consoles are shipped disassembled for easy installation. Each model design is product specific to achieve the best possible fit. Chassis components are made of 19mm MDF to provide strength and durability with minimal acoustical influence. Open chassis design defeats thermal buildup and permits easy cable access. Enclosed utility area behind meter-bridge separates, conceals, and protects vital gear and cabling. Detachable lids mounted on adjustable hinges and full-length back access panel provide easy access to utility areas. Multiple cable grommets in back main platform provide convenient cabling access. *Free shipping within the continental United States.

Dual lid design allows access to utility areas without having to clear entire bridge.

Most models offer on-board rack space to put crucial outboard gear at your fingertips.

Argosy quality in a smaller, non-expandable format.

Removable back access panel provide access to cabling and equipment.

Enclosed utility area behind meterbridge separates and conceals cabling.

One piece, full length, padded armrest provides comfort for extended hours of use.

Steel leg assemblies. Open chassis design defeats thermal buildup and permits easy cabling access.

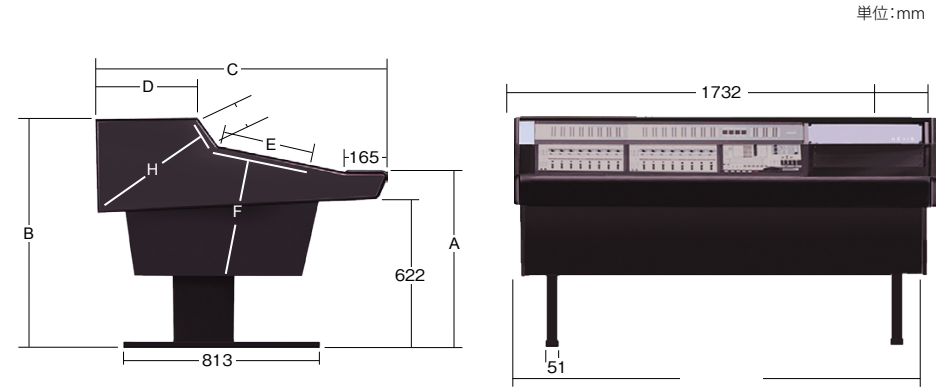

單位:mm

單位:mm

70 Series for	A height	B height	C depth	D depth	E rack sp	F min. depth	G rack sp	H min. depth
Digidesign Control 24	724	1016	1067	235	5 sp.	387	7 sp.	152-355
Digidesign ProControl	736	940	1130	387	8 sp.	394	2 sp.	198
Mackie 8 Bus	724	940	1130	387	8 sp.	362	3 sp.	362
Mackie D8B	724	940	1067	387	6 sp.	400	2 sp.	279
Mackie DXB	736	940	1130	387	3 sp.	406	6 sp.	210
Panasonic DA-7	724	1016	1067	343	7 sp.	387	4 sp.	356
Sony DMX-R100	749	940	1067	330	4 sp.	394	5 sp.	267
SoundCraft Ghost	749	940	1130	356	8 sp.	387	2 sp.	336
Tascam DM24	724	1016	1130	235	5 sp.	387	7 sp.	152-355
Tascam DM3200/DM4800	724	1041	1194	330	10 sp.	400	3 sp.	305
Tascam FW1884	724	940	1067	387	6 sp.	400	2 sp.	279
Yamaha DM2000	736	1029	1270	298	11 sp.	400	3 sp.	273
Yamaha O2R/O2R.96	749	1029	1194	254	11 sp.	406	3 sp.	229

specifications

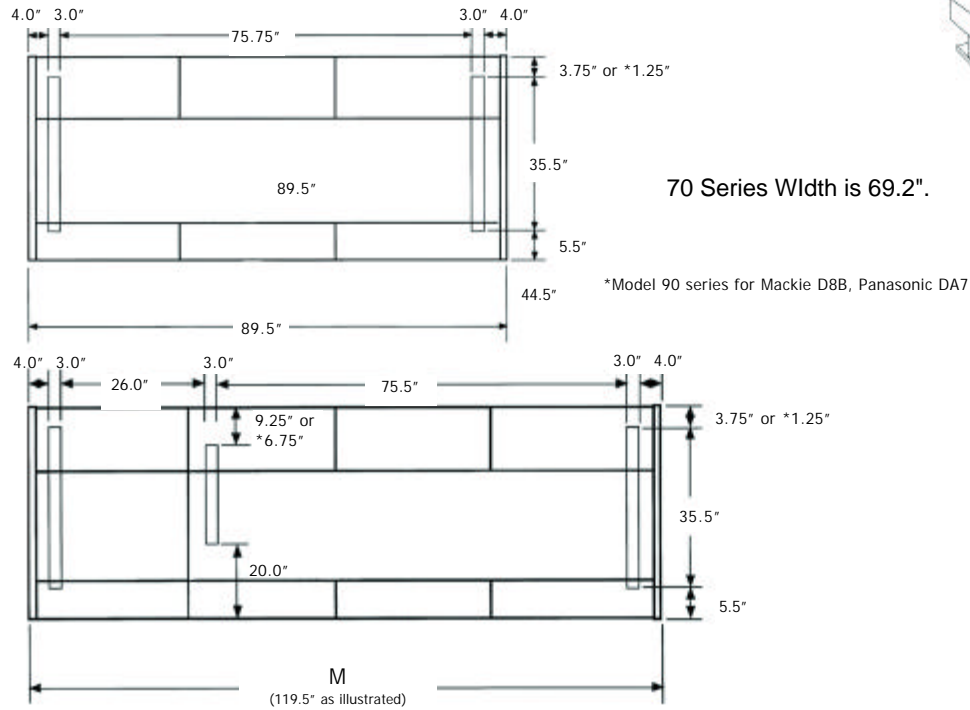

70 Series Width is 69.2".

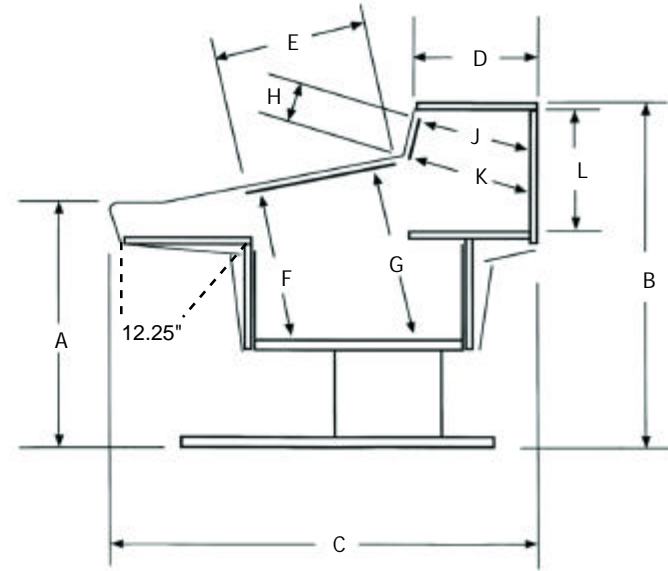

	A	B	C	D	E	F	G	H	J	K	L	expandable	Leg Set	End Panels	Armrest segment	Access Lids	M width	Est. Wt. lb.
	height	height	depth	depth	rack sp.	min. depth	min. depth	rack sp.	min. depth	min. depth	int. height							
Digidesign ProControl																		
90PC8, 16, 24, 32	29.0"	37.0"	44.5"	15.5"	8 r.u.	15.5"	18.25"	2 r.u.	17.0"	11.75"	10.125"	yes	1.5 x 3	32mm	3	3	89.5"	380-440#
90PC32E	"	"	"	"	"	"	"	"	"	"	"	"	"	"	4	4	119.5"	560#
Mackie D8B																		
90D8B-RC, RR, 2D8B	28.75"	37.0"	42.0"	15.25"	6 r.u.	15.75"	17.75"	2 r.u.	15.0"	11.0"	10.125"	yes	1.5 x 3	32mm	3	3	89.5"	360-440#
902D8B-R, C	"	"	"	"	"	"	"	"	"	"	"	"	"	"	4	4	119.5"	550-570#
902D8B-RCC	"	"	"	"	"	"	"	"	"	"	"	"	"	"	5	5	149.5"	640#
Mackie 8.bus																		
9024, 32, 48, 56	28.75"	37.0"	44.5"	15.0"	8 r.u.	14.25"	16.25"	3 r.u.	14.25"	15.5"	10.125"	yes	1.5 x 3	32mm	3	3	89.5"	340-430#
9056G	"	"	"	"	"	"	"	"	"	"	"	"	"	"	4	4	119.5"	460-490#
9080G	"	"	"	"	"	"	"	"	"	"	"	"	"	"	5	5	149.5"	640#
Panasonic DA7																		
90-DA7-RR, RRC, 2DA7-R	28.75"	40.125"	42.0"	13.5"	7 r.u.	15.25"	17.5"	4 r.u.	14.0"	15.0"	13.25"	yes	1.5 x 3	32mm	3	3	89.5"	400-430#
902DA7-CCR	"	"	"	"	"	"	"	"	"	"	"	"	"	"	4	4	119.5"	490#
SoundCraft Ghost																		
90G24, 32	29.5"	37.0"	44.5"	14.0"	8 r.u.	15.25"	17.25"	2 r.u.	13.25"	13.5"	10.125"	yes	1.5 x 3	32mm	3	3	89.5"	360-430#
90G56E	"	"	"	"	"	"	"	"	"	"	"	"	"	"	4	4	119.5"	500#
Yamaha O2R																		
90102R, 202R	29.0"	40.125"	44.5"	11.25"	10 r.u.	15.75"	18.0"	3 r.u.	10.5"	11.0"	13.25"	yes	1.5 x 3	32mm	3	3	89.5"	380-430#
90202RG, 302RG	"	"	"	"	"	"	"	"	"	"	"	"	"	"	4	4	119.5"	500-560#