

FEATURES AND TECHNICAL SPECIFICATIONS

RAVEN



RAVEN workstations are shipped disassembled for easy installation. *Free shipping within the continental United States.

Structural components are made of 19mm and 32mm MDF to provide strength and durability with minimal acoustical influence. Most components are given a powder coated finish. Modified trapezoid-shaped desk and "rack 'n roll" base units feature bevel relief for operator comfort. Open design promotes sonic transparency and defeats thermal buildup while permitting unobstructed access to gear and cabling.

Rack-N-Roll H10

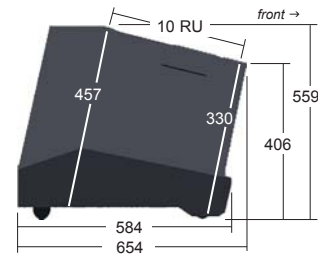

Rack 'n Roll Width: 23.1"

Rack-N-Roll L10

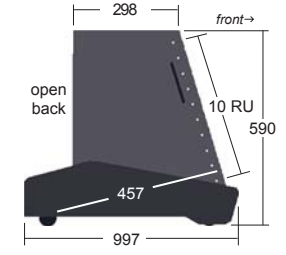

Rack 'n Roll Width: 23.1"

单位:mm

单位:mm

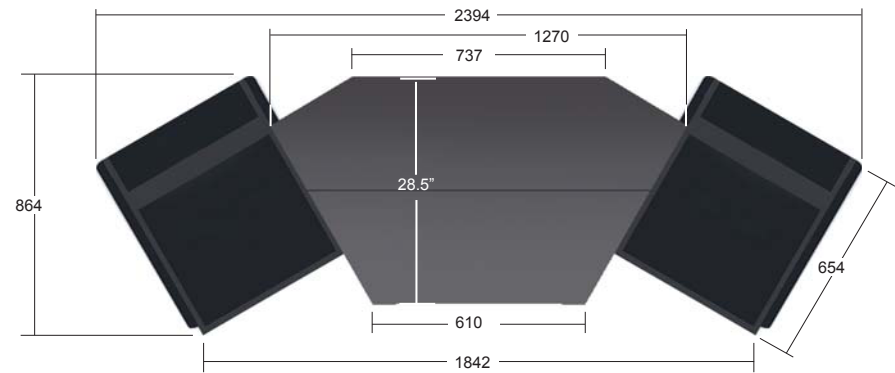
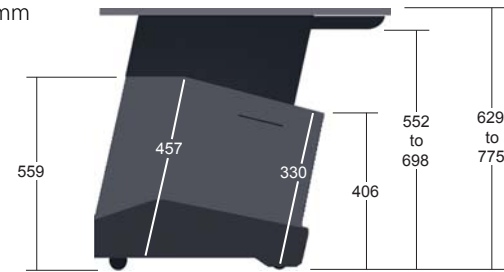

单位:mm